



**Pascal 2005, SD Version, 1-Phase  
Motor, 180–254 V, 50/60 Hz,  
CE/UL/CSA**



Similar Image

**Pascal 2005, SD Version, 1-Phase Motor, 180–254 V,  
50/60 Hz, CE/UL/CSA**

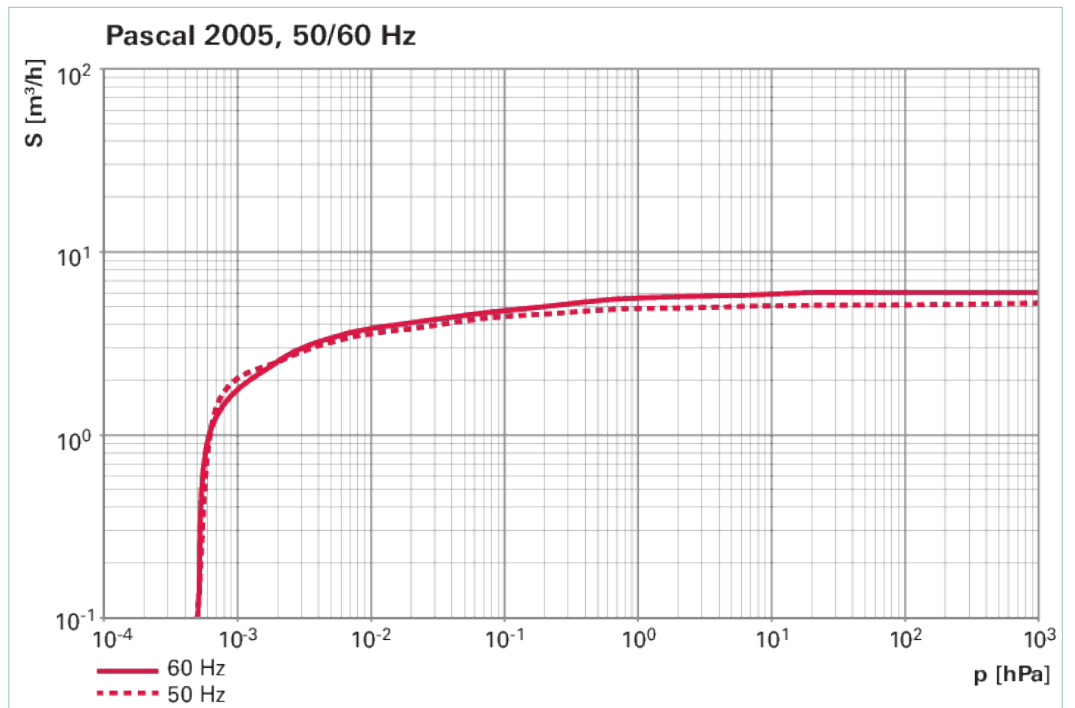
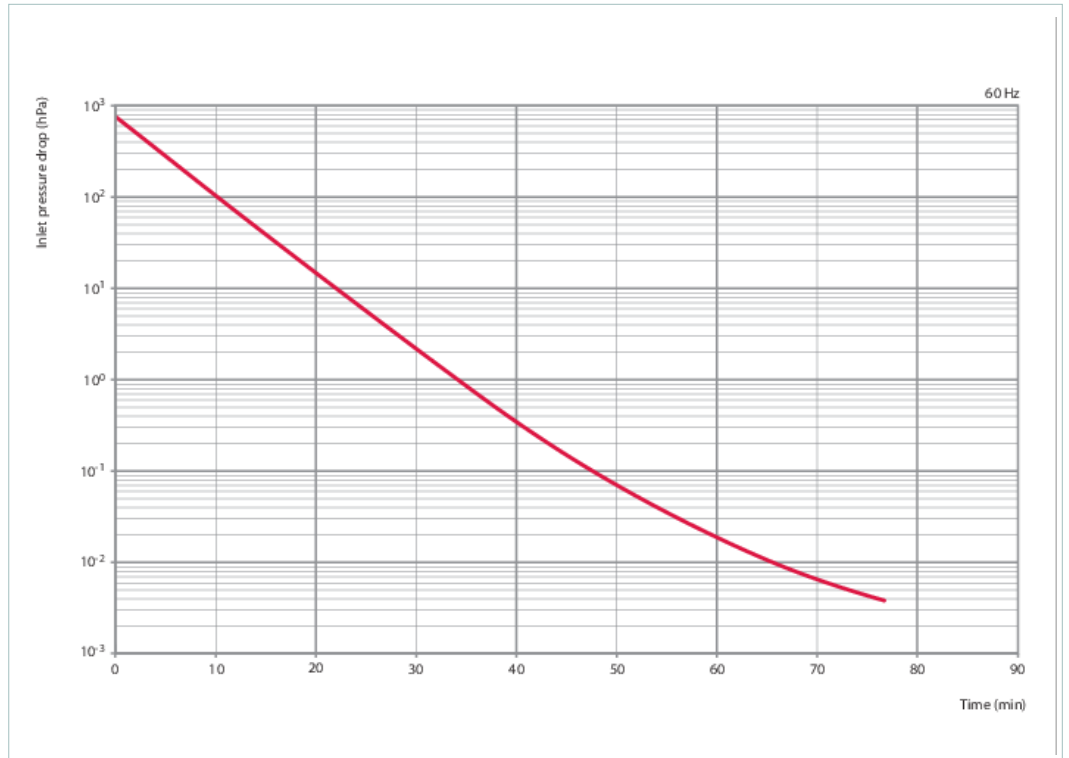

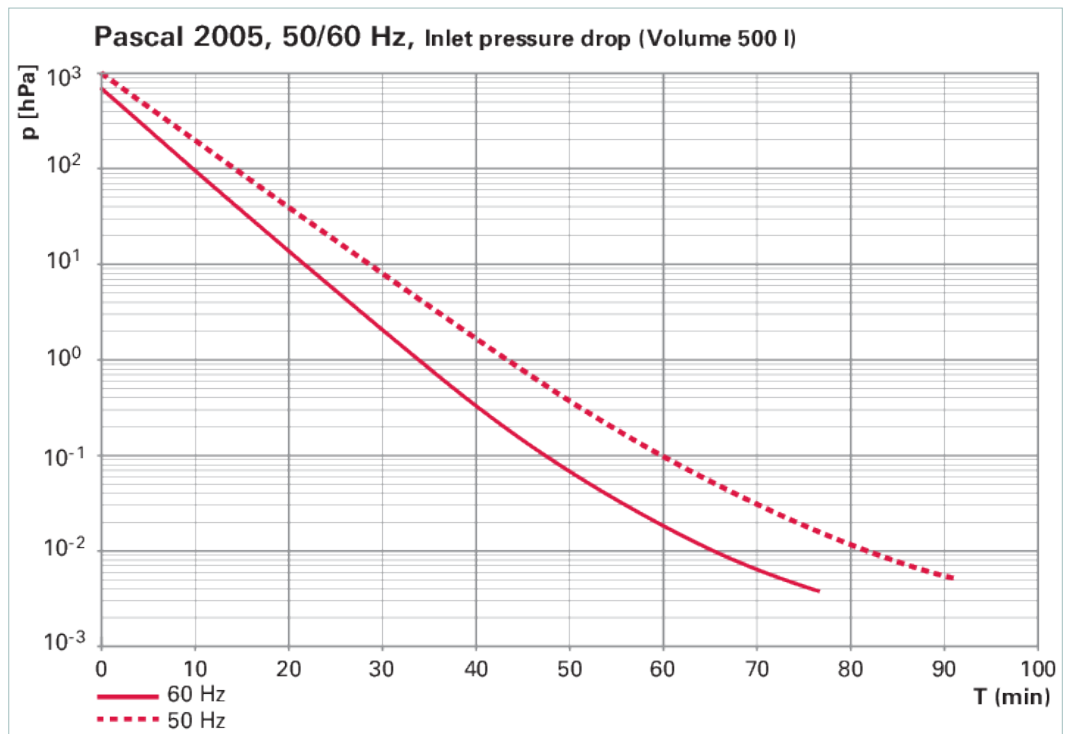

**Dimensions**

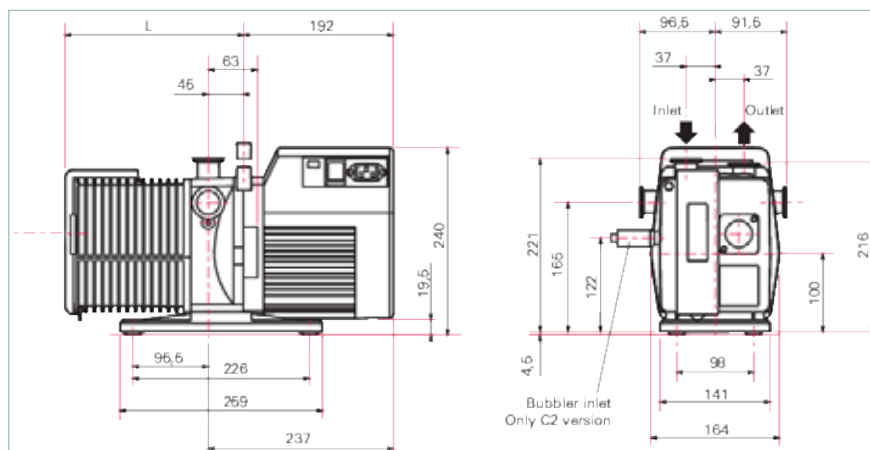

L 228 mm

Technical Data	Pascal 2005, SD Version, 1-Phase Motor, 180–254 V, 50/60 Hz, CE/UL/CSA
Connection flange (in)	DN 25 ISO-KF
Connection flange (out)	DN 25 ISO-KF
Pumping speed at 50 Hz	5 m <sup>3</sup> /h   2.94 cfm   83.33 l/min
Pumping speed at 60 Hz	6 m <sup>3</sup> /h   3.53 cfm   100 l/min
Final pressure	5 · 10 <sup>-4</sup> hPa   3.75 · 10 <sup>-4</sup> Torr   5 · 10 <sup>-4</sup> mbar
Final pressure with gas ballast	1 · 10 <sup>-2</sup> hPa   7.5 · 10 <sup>-3</sup> Torr   1 · 10 <sup>-2</sup> mbar
Final pressure without gas ballast	5 · 10 <sup>-4</sup> hPa   3.75 · 10 <sup>-4</sup> Torr   5 · 10 <sup>-4</sup> mbar
Motor type	1-ph motor
Mains connection: voltage 50 Hz	180 – 254 V
Mains connection: voltage 60 Hz	180 – 254 V
Mains cable	Yes, EU mains cable
Operating fluid	Mineral oil
Rated power 50 Hz	0.45 kW
Rated power 60 Hz	0.55 kW
Protection degree	IP43

<b>Technical Data</b>	<b>Pascal 2005, SD Version, 1-Phase Motor, 180–254 V, 50/60 Hz, CE/UL/CSA</b>
Weight	25 kg   55.12 lb

<b>Order number</b>	
Pascal 2005, SD Version	<b>205SDMHEM</b>

<b>Accessories</b>	
<b>Monitoring</b>	
<b>Oil/Operating fluid level monitoring</b>	
Oil level switch OLS 4	<b>104376</b>
<b>Other</b>	
Cold Trap, LN2, angled, DN 25 ISO-KF, 4" body, stainless steel / FPM	<b>FTNA-4-1002-NWB</b>
<b>Protection</b>	
<b>Catalyzer traps</b>	
URB 025, catalytic trap, 115 V	<b>PT U10 761</b>
URB 025, catalytic trap, 230 V	<b>PT U10 760</b>
<b>Condensate separators</b>	
KAS 25 L, condensate separator for pumping speeds up to 35 m <sup>3</sup> /h	<b>PK Z10 033</b>
<b>Dust separators/Inlet particle filters</b>	
SAS 25, Dust Separator, DN 25 ISO-KF	<b>PK Z60 508</b>
<b>Oil mist eliminators</b>	
Oil mist separator OME 25 S	<b>104200</b>
OME 25 M, oil mist separator for pumping speeds up to 12 m <sup>3</sup> /h	<b>PK Z40 157</b>
<b>Oil return units from oil mist eliminators</b>	
Oil Return Unit ODK1 from Oil Mist Separator	<b>104360</b>
Oil Return Unit ODK 2 from OME 25, Solenoid Valve 230 V 50/60 Hz, Pascal 2005–2021	<b>104361</b>
Oil Return Unit ODK 2 from OME 25, Pascal 2005–2021, Solenoid Valve 115 V, 60 Hz	<b>104362</b>
Oil Return Unit ODK 2 from OME 25, Pascal 2002–2021	<b>104364</b>
Oil return unit ODK 2 from OME 25, Pascal 2005–2021, solenoid valve 24 V DC	<b>104365</b>
<b>Sorption traps</b>	
Sorption trap ST 25 S	<b>104107</b>
<b>Gas ballast valves, magnetic</b>	
Automatic Gas Ballast AGB 4, 230 V, 50/60 Hz	<b>104086</b>
Automatic gas ballast AGB 4, 115 V	<b>104087</b>
Automatic Gas Ballast AGB 4, 24 VDC	<b>104089</b>
Automatic Gas Ballast AGB 4, 200 V, 50/60 Hz	<b>104366</b>
<b>Consumables</b>	
A120, hydrocarbon oil, 2 L	<b>068099</b>
A111, mineral oil, 2 L	<b>064655</b>
A102, hydrocarbon oil, 2 L	<b>010996</b>
A119, hydrocarbon oil, 1 L	<b>103855</b>
A121, hydrocarbon oil, 1 L	<b>102724</b>
D1, synthetic diester based oil, 1 l	<b>PK 005 875 -T</b>